

CUMMINS SERIES



# MODEL AC75 KAN GENSET 75KVA/60KW



## General Performance Data

Prime Power	68KVA/54KW	Engine	Brand	Cummins
Stand by Power	75KVA/60KW		Model	4BTA3.9-G2
Frequency/Speed	60Hz/1800rpm	Control module	Deepeat 6120	
Rated Power Factor(cosφ)	0.8	Rated Current	177A	
Standard Voltage	127V/220V	Capacity of Breaker	225A	
Phases	3	Starting Voltage	DC24V	

## Fuel consumption

Rated output	Fuel consumption rate	
	Fuel consumption rate (g/KW.h)	Fuel consumption rate (L/h)
100%Standby	218g/KW.h	17.4L/h
100%Prime	219g/KW.h	15.9L/h
75%Prime	223g/KW.h	12.2L/h
50%Prime	240g/KW.h	8.7L/h
25%Prime	305g/KW.h	5.5L/h

## Standards followed

ISO9001	ISO14001
ISO8528	ISO12100
ISO13849	EN12601
GB12786	GB/T2820
IEC60034	IEC60204
CE	RETIE

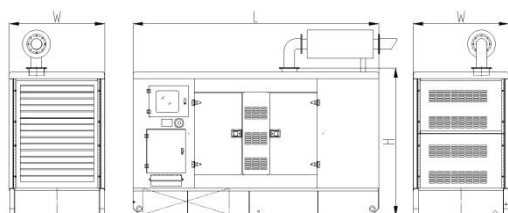
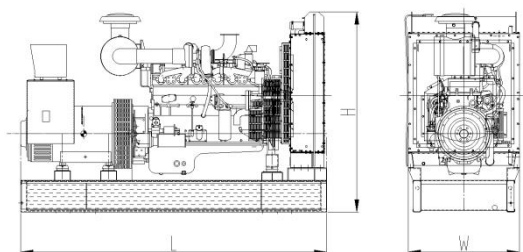

## Dimensions and Weights

Type	Open	Silent
Length(mm)	1980	2350
Width(mm)	750	1000
Height(mm)	1350	1540
Weight(kg)	800	1250
Base fuel tank volume (L)	125	125

## Engine specification

### Basic parameter

Manufacturer	dongfeng Cummins
Model	4BTA3.9-G2
No. of cylinder	4
Type	4 cycle, Vertical In-line
Prime Power	60kw /80HP
Standby Power	66kw /88HP
Induction system	Turbocharged & Aftercooled
Governor	Electronic speed
Bore x Stroke	102x120mm
Displacement	3.9L
Compression ratio	18.0:1
Oil Capacity(Total)	10.9L
Coolant Capacity(Engine only)	7.2L
Cranking Motor Voltage	DC24V

### Fuel System

Type Injection system	BYC Type A inline pump
Min. Allowable flow of fuel to fuel pump	14.1 L/h

### Lubrication system

Oil Pressure	
---Idle speed	207kPa
---Rated speed	345kPa
Max. allowable oil temperature	121°C
Offset sump oil capacity: low/high	9.5 /8.5L
Total system capacity	10.9L

### Air induction system

Maximum allowable intake air restriction	
---with clean filter element	3.7kPa
---with dirty filter element	6.2kPa
Intake Air alarm temperature	82°C

### Exhaust system

Max. allowable back pressure	10kPa
Standard exhaust pipe diameter	75mm

### Cooling system

Coolant capacity	
---Engine only	7.2L
---Total system	20.8 L
---With heat exchanger	13.6L
Standard thermostat(modulating) range	82-95 °C
Minimum cap pressure	69kPa
Max. allowable top tank temperature for stand by/prime power	104/100 °C

### Electric system

Min. recommended battery capacity (24V)	
---10°C(50°F) & above- 0°F CCA	312
--- 0°C(32°F) to 10°C(50°F)- 0°F CCA	312
---18°C(0°F) to 0°C(32°F)- 0°F CCA	312
Max. allowable resistance of Starting circuit	0.002ohm
Starter(heave,Anode)	DC24V
Battery recharge system, negative ground	40ampere

## Alternator specification

Phases	3	Coating	Vacuum impregnation
Poles	4	Insulation class	H
Power factor(cosφ)	0.8	Protection	IP23
Winding connection	Star	Excitation system	Self-excited
Winding pitch	2/3	Bearing	Single Bearing
Voltage regulator type	AVR	Coupling	Flexible disc

## Control system Introduction

### Deepsea 6120 Auto start & auto mains failure control panel

**Deepsea 6120** is an auto mains failure controller for single generator, it can monitor and protect the generator working all the time. it has a LCD display which clearly shows the status of the engine. this controller include seven inputs and six outputs. This controller can also be programmed using the front panel or by using DSE configuration Suite PC software

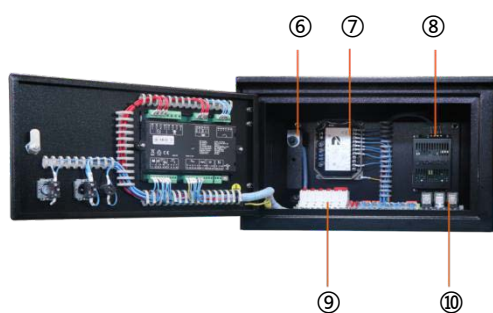
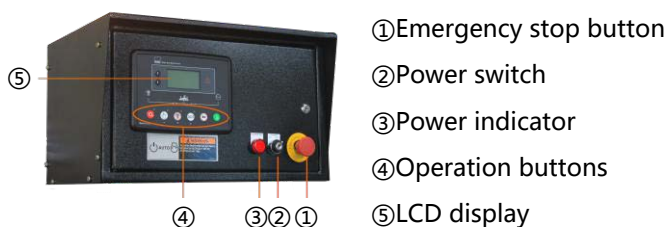

- ⑥ Voltage and frequency trimmer
- ⑦ Governor
- ⑧ Charger
- ⑨ MCB
- ⑩ Relay

### Key Features:

- Auto start/stop, load transfer and alarming of generator
- Remote start on or off load
- With hierarchical loading function
- Multiple start/stop cycles can be preset
- 3 phase generator and mains voltage monitoring.
- Generator/load power detection(kW, kVA, kVA<sub>r</sub> PF)
- Overload protection (kW)
- Load current monitoring and protection
- Engine speed protection
- Engine pre-heat
- Engine start idle & stop idle
- Battery voltage monitoring
- Start under the low battery
- 4 active outputs
- 4 digital inputs and 3 analogue inputs.
- 6 Custom digital input
- 6 outputs(4 configurable on magnetic pick-up, 6 configurable on Canbus version)
- DSE2130,DSE2157,DSE2548 expansion module can be connected
- Support 0-10V or 4-20mA oil pressure sensor

### Main features:

- Multi language display
- Mains failure self starting
- The running time of the engine can be recorded to facilitate the maintenance and repair of the unit
- User-friendly set-up and button layout
- LCD display can display multiple parameters at the same time
- Support EFI engine
- IP65 rating (with optional gasket)
- PC and front panel configuration
- 100 event records
- Data recording and trend analysis

### Protection:

- Two sets of protection parameters can be preset
- Normal alarm, electrical trip and shutdown alarm can be set to effectively monitor the engine speed,oil pressure, water temperature and oil level, as well as the frequency, voltage, current and power of the alternator, for complete engine/alternator protection
- Low Oil Pressure
- High water Temperature
- High voltage and low voltage
- Overspeed
- Emergency stop
- Fail to start

## Soundproof Canopy Introduction

### Silent Type:

- The vertical angle structure makes the appearance beautiful
- High quality coating powder, chemical surface treatment & 100-120um coating thickness greatly improving the anti-corrosion and anti rust level
- carbon hinge & door lock are beautiful and anti-rust
- 1.8mm cold rolled plate used makes the body more solid
- The bottom forklift and loading port design enables easy loading and unloading
- 180° revolvable and disassemble door for easy maintenance.
- The drainage outlets are all connected to the outside for easy operation
- The sufficient air in & out design ensure long-term and stable operation of the unit
- Isolation net is designed for air inlet, exhaust outlet and muffler outlet to prevent objects from entering the unit
- High density foam used inside effectively reduces noise
- The built-in base fuel tank with fuel filler set on the shell facilitates refueling
- Emergency stop button mounted on the canopy exterior for urgency.



## Decomposition diagram introduction

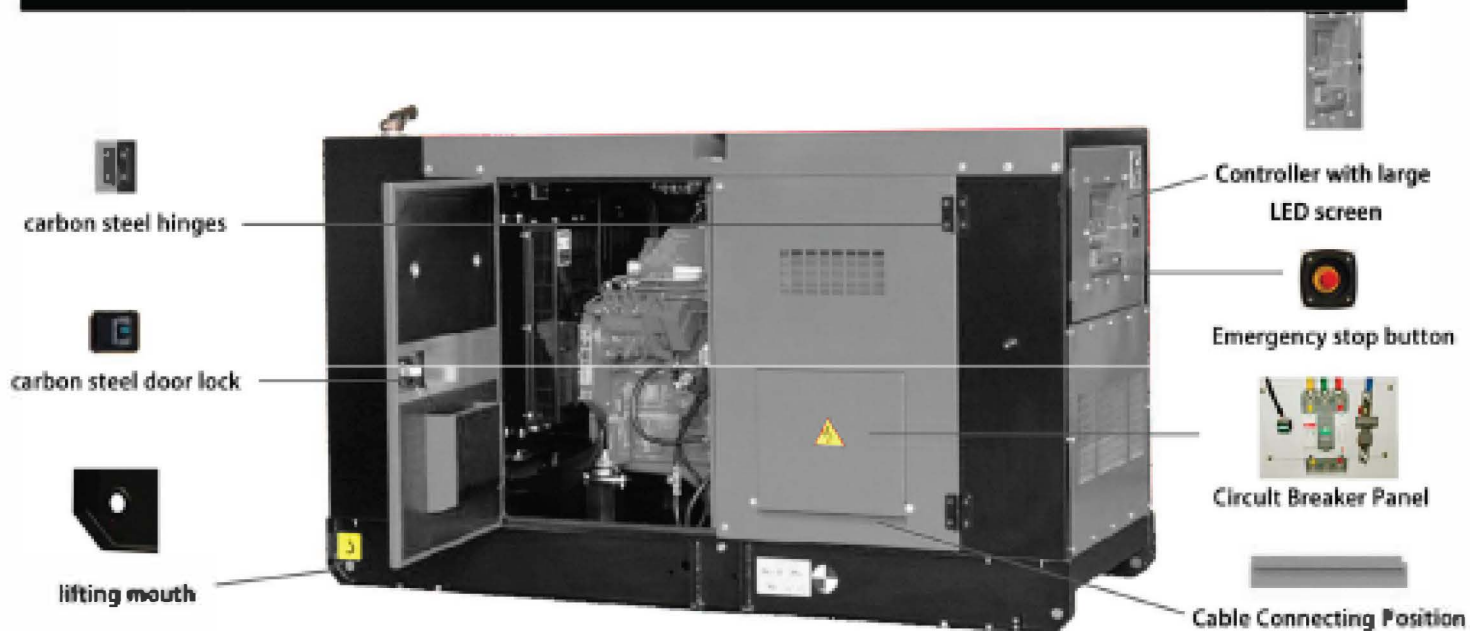

## Standard supply scope:

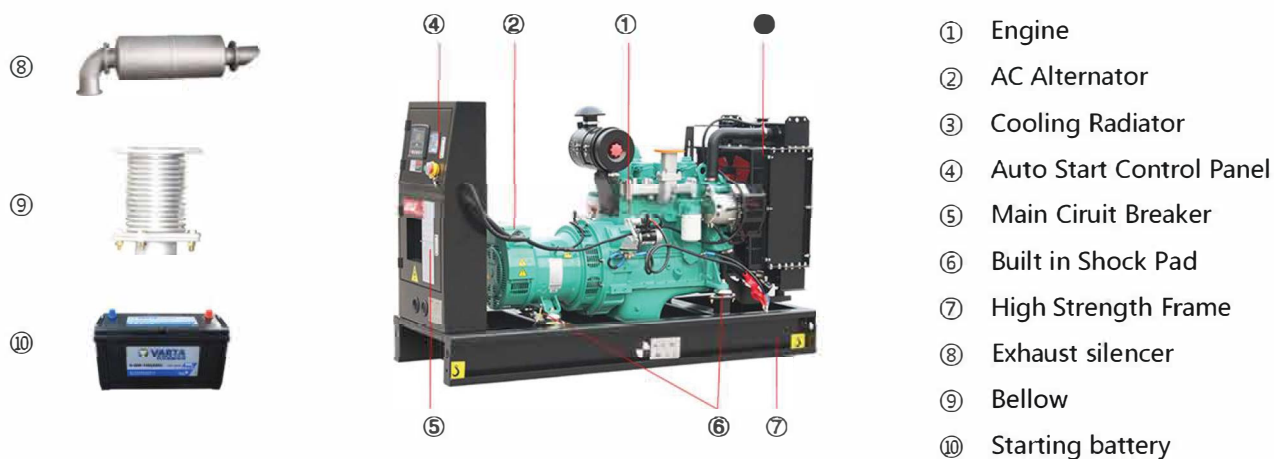

## Optional supply scope:

Genset	Engine	Alternator	Control system
<ul style="list-style-type: none"> <li>• Tool box</li> <li>• Base fuel tank</li> <li>• External daily fuel tank</li> <li>• Trailer</li> </ul>	<ul style="list-style-type: none"> <li>• Fuel heater</li> <li>• Fuel and water separator</li> </ul>	<ul style="list-style-type: none"> <li>• Temp. detector for winding and bearing</li> <li>• PMG</li> <li>• Antirust, mildew and salt fog treatment</li> <li>• Anti condensation heater</li> </ul>	<ul style="list-style-type: none"> <li>• ATS</li> <li>• Synchronization System</li> <li>• Adjustable earth relay</li> </ul>
Breaker	Fuel system	Lub-oil system	Cooling system
<ul style="list-style-type: none"> <li>• ABB</li> <li>• Schneider</li> </ul>	<ul style="list-style-type: none"> <li>• Low fuel level alarm</li> <li>• Auto Fuel Pump</li> <li>• T Valve</li> </ul>	<ul style="list-style-type: none"> <li>• Lub oil heater</li> <li>• Temp.-sensor</li> <li>• Oil drain Pump</li> </ul>	<ul style="list-style-type: none"> <li>• Elec.coolant Heater</li> </ul>